

Freshware have a comprehensive range of products for window & patio door locking hardware.

Freshware have a comprehensive range of products for window & patio door locking hardware. We've bolstered the range of products to comply with the newly introduced "Falling From Windows" regulations. Branded under the "Carbine" banner, a name synonymous with the highest quality locking products, the security, look and quality of the products is assured. With these new additions, as well as our existing range, your choice of window and patio door locking hardware has been made much easier. This brochure is a collection of the range of Carbine window locks and patio bolts.

CARBINE

THE NEXT GENERATION IN LOCKING



Sash Window Locks

Pg2



Sliding Aluminium Window Locks

Pg3



Mini Vent Lock

Pg4

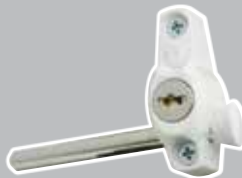

Multi bolt & multi bolt cable

Pg5



G70 awning stop & G10 sash fasteners

Pg6



Mini push lock & C500 patio bolt



Pg7



Heavy Duty Patio Bolt

Pg8





Carbine locks featuring this logo have been tested both in-house and by an official testing laboratory to ensure compliance on several different types of windows.

Copies of our test certificates are available upon request.



Carbine Sash Window Lock CSL Series



Carbine window locks offer a higher level of modular security for all sash window applications. Ease of installation and high security make this product the leader in its field.

Features include:

- Stylish design
- Easy installation
- Easily rekeyable
- Keyed alike and in multiple groups if required
- Available in finishes of white, black, brown & silver



Carbine Vent Window Lock CVL Series



Carbine window locks offer a higher level of modular security for all sliding window applications.

Features include:

- Stylish design
- Easy installation
- Easily rekeyable
- Designed to suit most aluminium sliding windows
- Suitable for left and right hand fitting, front mount and side mount
- Keyed alike and in multiple groups if required
- Available in finishes of white, black, brown, silver, doeskin & primrose



Kids Don't Fly -

Protection from falling from windows regulations

It is critical for all locksmiths with installers to familiarize themselves with the new regulations as this campaign will be generating loads of activity over the next 6 months. Below is an excerpt from the new regulations to help you choose compliant locks.

On 1 May 2013 the National Construction Code & BCA regulations were modified to include new laws regarding protection for openable windows. By 13th March 2018 all relevant windows must comply with these regulations.

D2.24 Protection of openable windows

(a) A window opening must be provided with protection, if the floor below the window is 2 m or more above the surface beneath in-

- (i) a bedroom in a Class 2 or 3 building or Class 4 part of a building; or
- (ii) a Class 9b early childhood centre.

(b) Where the lowest level of the window opening is less than 1.7m above the floor, a window opening covered by (a) must comply with the following:

(i) The openable portion of the window must be protected with-

- (A) a device to restrict the window opening; or
- (B) a screen with secure fittings.

(ii) A device or screen required by (i) must-

- (A) not permit a 125 mm sphere to pass through the window opening;
- (B) resist an outward horizontal action of 250 N against the-
 - (aa) window restrained by a device; or
 - (bb) screen protecting the opening; and
- (C) have a child resistant release mechanism if the screen or device is removed, unlocked or overridden.

Note: This excerpt should be read in conjunction with the complete BCA regulations to ensure compliance with all relevant standards

<http://www.health.nsw.gov.au/childsafety/pages/kids-dont-fly.aspx>



Carbine Mini Vent Lock CMVL Series

The CMVL Mini Vent Lock is a fantastic addition to our Carbine window lock range.

Designed to comply with Falling from Windows regulations, the CMVL has some great features and will be the lock of choice for compliance.

- Incredibly easy to install – supplied with a drilling template so it fits in just seconds
- No screw fixing required
- Locks into the window track behind a sliding aluminium window
- Solid zinc diecast construction for better strength
- Includes a spacer plate to allow fitting on different track thicknesses
- Keyed alike and in multiple groups if required
- Available in finishes of white, black & silver



Carbine Multi Bolt CMB Series



Carbine window locks offer a higher level of modular security for all general use window applications.

Features include:

- Stylish design
- Easy to install
- Easily rekeyable
- Designed to suit a variety of window applications
- Supplied with 3 different bolts for various window types
- Bolt can be locked through a front or side projection
- Keyed alike and in multiple groups if required
- Available in finishes of white, black, brown, silver, doeskin and polished brass



Carbine CMB Multi Bolt Cable

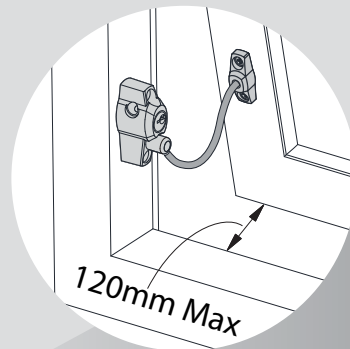

A great addition to the Carbine window lock range. Limits window movement to add safety and security to many common window types.

- Tested and complies with Falling from Windows Regulations
- Very easy to install
- Suitable for awning, casement, double hung sash and sliding windows
- Can be purchased as cable only or as a kit with multi bolt locks
- Multi bolt locks now available supplied without the 3 bolts, ideal for fitting with the cable attachment
- Available in black or white finish cable (bracket and locking bolt are chrome finish)



Carbine Awning Stop G70 Series



Carbine G70 offers a unique solution for sliding window security where you may not have locks or keys available.

The G70 can be fitted to most sliding and double hung aluminium window and doors.

- Torx key operation to tighten or loosen, provided with pack
- Fits window tracks from 1mm to 2.5mm thickness
- 6 locks per pack
- Easy to install and use



Carbine Sash Fastener G10 Series

The Carbine G10 provides a simple solution to locking problems for common low security timber windows. Simply drill one hole, insert the receiver, screw in the bolt and the window is secured. The special drive key can be used to lock or unlock at any time. Features include:

- Screw in sash bolt
- Suitable for double hung or sliding timber windows
- Requires 11mm hole 65mm deep for fitting
- Unobtrusive once fitted
- Brass finish
- Very easy to install
- Special secure drive key included



Carbine Mini Push Lock CMP Series



Carbine window locks offer a higher level of modular security for all general use window applications. Ease of installation and high security make this product the leader in it's field.

- Designed to suit casement window applications
- Patented locking bolt mechanism offers easy handing, bolt insertion and a quick release
- Locking bolt covers screws so no need for one way screws
- Locking bolt can be locked and retained in both locked and unlocked positions
- Keyed alike and in multiple groups if required
- Available in finishes of white, black, brown, silver, primrose and polished brass



Carbine Patio Bolt C500 Series

Carbine patio bolts offer a higher level of modular security for all general use window and door applications. Ease of installation and high security make this product the leader in its field. Features include :

- Suitable for use on sliding, inward opening and French style doors
- Easily rekeyable
- 9.5mm mild steel bolt, duplex nickel plated with 50mm bolt extension
- Bolt can easily be removed for left or right handing
- Fixing screws located under the bolt with no need for tamper proof screws
- Zinc plated strike and countersunk screws included
- Bolt can be locked in the open and closed position
- 4mm packers that can stack
- Keyed alike and in multiple groups if required
- Available in finishes of white, black, brown, silver, primrose, doeskin, chrome plated and polished brass



Carbine Patio Bolt CHDPB Series



Carbine Patio Bolts offer a higher level of modular security for all patio bolt applications. Changeable functions and a high security bolt make this product the leader in its field.

- Easy to install
- Retrofits for Carbine C500, Lockwood 680 and Whitco patio bolts
- Uses the same bolt as the C500 patio bolt
- 9.5mm diameter high tensile bolt (hard chrome plated)
- Reversible quick release bolt mechanism
- Bolt can be locked in the open/closed position
- All mounting screws are concealed
- A high security diecast receiver is available as a spare part in each finish
- Packing plates available
- Extended bolts of 50mm available
- Keyed alike and in multiple groups if required
- Available in finishes of white, black, brown, silver and polished brass



Easy rekey from the front!

